

# 3 Interactive Demos



*Michael Klein, Andrej Itrich and Thomas Eppler*

# **Interactive Demonstration showing a Remote Lab using the Fischertechnik learning Factory 4.0**

## Abstract

A fully automated remote lab based on a fischertechnik learning factory to reproduce Industry 4.0 and Internet of Things processes. Participants can control and analyze the lab via the university cloud, independently of time and location.

## Keywords

fischertechnik learning factory 4.0, MQTT, OPC/UA

## **1 Introduction**

The fischertechnik learning factory is a manufacturing plant that consists of fischertechnik elements and is used to simulate a digitalized factory. The simulation reproduces the ordering process, the production process, the delivery process, and the storage process in digitalized process steps.

The factory has several stations such as a vacuum gripper robot, an automated high-bay warehouse for storing nine colored workpieces, a multi-processing station with a simulated kiln and milling machine, a sorting line with color recognition, a delivery and pickup station, and a sensor unit station with an integrated swiveling camera for monitoring the factory.

The individual workpieces are tracked and described by NFC (Near Field Communication). This allows the tracking and visibility of the current status of the workpieces in the manufacturing process.

## 2 The fischertechnik learning factory 4.0

### 2.1 MQTT

The factory is controlled with a Siemens PLC control (industry standard). The entire communication within the factory takes place with MQTT. The messages use the JSON format.

MQTT communication makes it possible for you to write your own software to control the fischertechnik learning factory.

In addition to the web-based dashboard, provided by fischertechnik to control the learning factory, it is also possible to trigger the ordering process via Python scripts. With this tiny client, it is possible to display the current stock of the high-bay as well as the current camera image. The current status of a station can also be requested.

This data is sent to the university's MQTT broker using an MQTT cloner (Python script), which runs on the learning factory's Raspberry Pi, where the data is processed and distributed to different systems via Apache Nifi.

### 2.2 Apache Nifi

Apache Nifi is a data ingestion system with which data routes from a data source, in this case the fischertechnik factory, to a data sink, in this case various database management systems, can be built up graphically without having to be coded. The statuses of the stations and the camera images are stored in Hadoop's distributed file system HDFS. The sensor data is sent to AWS RedShift in the Amazon Cloud. The sensor data are graphically processed using a Python script.



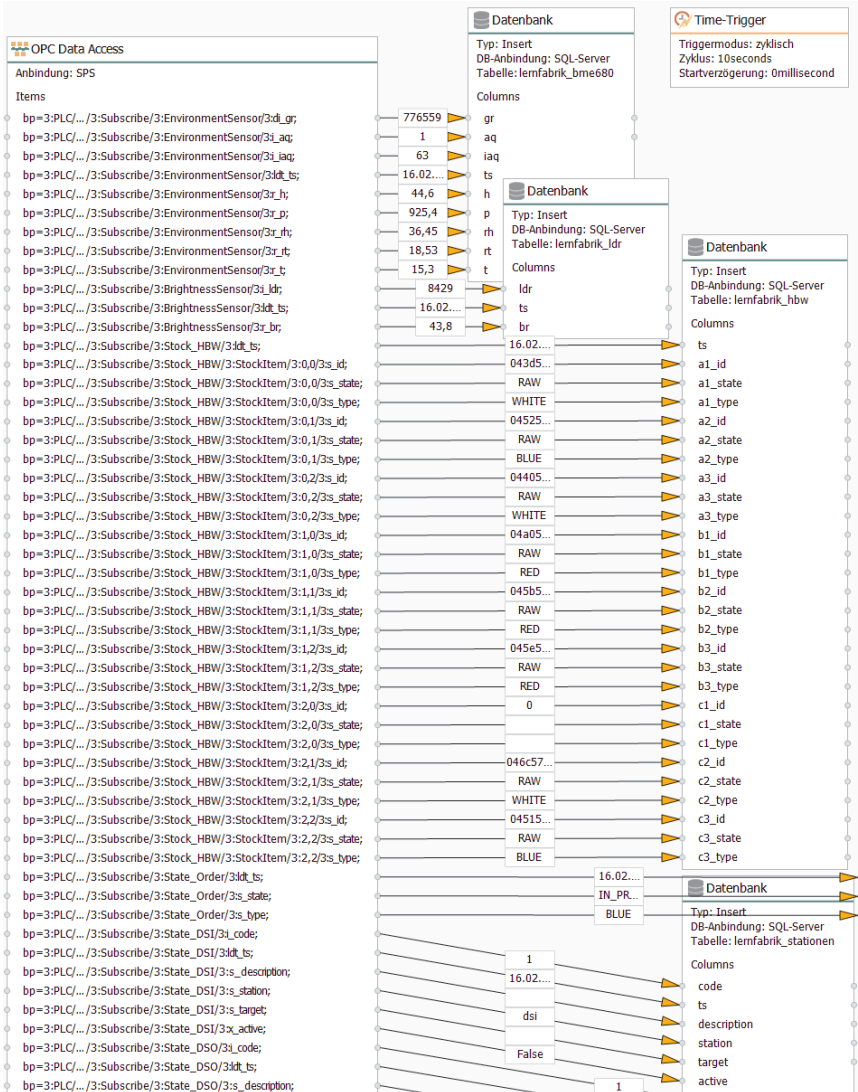

Figure 2: OPC-Router project

## 2.4 Communication structure

The communication structure of the system described above is visualized in the following figure:

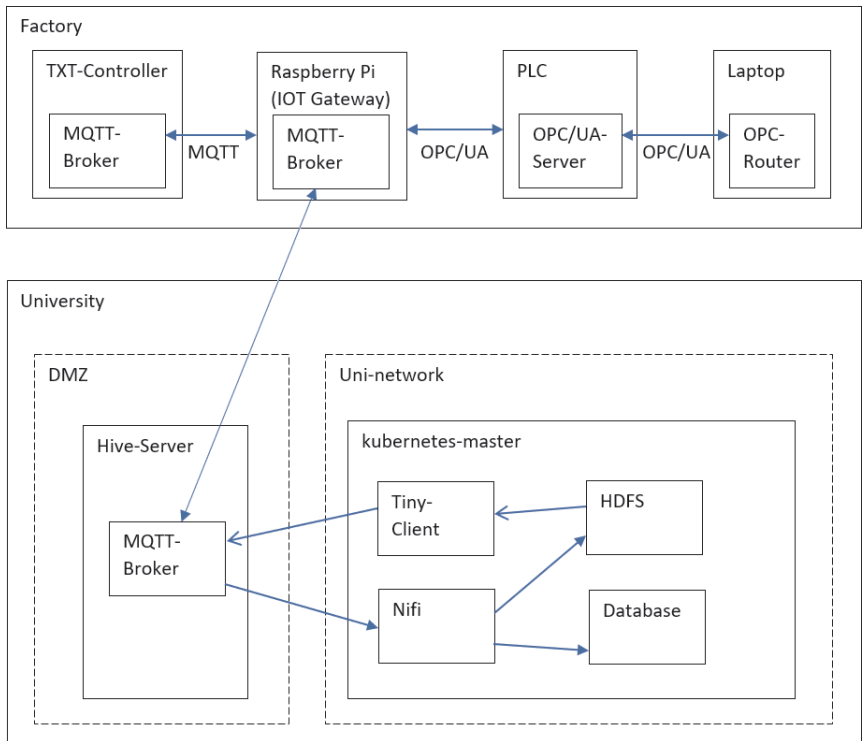

Figure 3: Communication structure

## 2.5 Study materials and exercises

The ordering and storage process is described in detailed study materials. Exercises including solutions for the ordering and storage process, the data ingestion routes, and data evaluation and visualization deepen the understanding of communication with the learning factory.

The participants can access the system regardless of location and time and can carry out the exercises at any time. The fischertechnik system

was converted into a fully automatic and autonomously operating system. However, tests still have to show if the components installed by fischertechnik are fail-safe, and predictive maintenance functions still need to be developed in order to be able to detect the failure of a subsystem at an early stage.

## References

- fischertechnik, Alexander Steiger. (2021, September 26). MQTT-Interface [https://github.com/fischertechnik/txt\\_training\\_factory/blob/master/TxtSmartFactoryLib/doc/MqttInterface.md](https://github.com/fischertechnik/txt_training_factory/blob/master/TxtSmartFactoryLib/doc/MqttInterface.md)
- fischertechnik. (2021, September 27). Begleitheft Lernfabrik 4.0 Englisch. <https://www.fischertechnik.de/de-de/service/elearning/lehren/lernfabrik-4>

## Authors



Michael Klein  
Hochschule Albstadt-Sigmaringen, IAF  
Poststr. 6  
72458 Albstadt-Ebingen  
[klein@hs-albsig.de](mailto:klein@hs-albsig.de)



Andrej Itrich  
Hochschule Albstadt-Sigmaringen, IAF  
Poststr. 6  
72458 Albstadt-Ebingen  
[eichmann@hs-albsig.de](mailto:eichmann@hs-albsig.de)





Thomas Eppler  
Hochschule Albstadt-Sigmaringen, IAF  
Poststr. 6  
72458 Albstadt-Ebingen  
eppler@hs-albsig.de

