

*Giovanni Romagnoli, Dieter Uckelmann,
Davide Reverberi and Maria Ustenko*

Applied RFID in Logistics Testing RFID Technology for its Application in the Fast-Moving Consumer Goods and Apparel Industries¹

Further Contributors: Chiara Coldani, Gaia Codeluppi,
Giovanni Esposito, Leornado Rossi, Akbar Karimi

Keywords

Radio-frequency Identification (RFID), Logistics, Retail, Received Signal Strength Indicator (RSSI)

1 Preface

Overview

In this chapter, a research-oriented lecture on RFID application in logistics is provided. The chapter explains the theoretical background of UHF RFID and is driven by a user story, based on an industry-like scenario in a food & beverages supply chain. Indeed, the second section of this chapter will deep dive into the user story, allowing the reader to personify a supply chain management consultant into a pilot implementation of RFID technologies in the food & beverages sector. Also, the lecture presented in this chapter is strictly connected with practical lab experience. By means of QR codes, in fact, readers might be linked to supplementary resources, such as data repositories or even experiments, performed either in batch (i.e. readers specify the experimental settings, and then the experiment is performed and the results are provided at a later time) or remotely (i.e. readers become experimenters by remotely accessing and operating lab resources). When carrying out the lab experience, readers are encouraged to work in groups

1 giovanni.romagnoli@unipr.it

of 2–4 people to set and/or perform the experiments, and to analyze experimental results. The aim of this group work is to foster cooperative learning, especially when this chapter is adopted in higher or vocational education classes or courses.

Didactic fundamentals

Target group	Master's students in industrial, electrical, or computer engineering disciplines or professionals in supply chain management or logistics who want to deepen their knowledge of the topic of industrial RFID applications
Effort in lecture hours	16
Effort for self-study materials	34
Suggested Credit Points (CP)	2
Prerequisites	General: computer with online access, MS-Excel or compatible spreadsheet Specific: The experiment needs to be booked one month in advance
Necessary background	The reader is strongly advised to go through the RFID-tag testing chapter first
Additional information	Before the reader starts with the user story, we suggest leafing through the sections 2–4. If the reader feels confident about those topics, we suggest start with the user story in section 1 immediate. Conversely, a deeper look into the theory in sections 2–4 could provide the reader with the necessary theory to perform the experiments and analyze their results.

Learning Objectives and Skills

The goals of this learning chapter are that the students:

- know the components of an RFID system
- have an overview of the frequency ranges of the RFID technology
- understand how the backscatter communication of UHF RFID works and the difference between near field and far field antennas
- know which antenna polarizations exist and what is meant by ERP, EIRP, and RSSI
- acquire knowledge of the modulation, encoding, and anti-collision methods of UHF RFID systems
- know which factors influence the communication of an RFID system
- can measure RSSI curves to find out the influence of power and substrate on an RFID system
- are able to measure and calculate alpha and beta errors in different system configurations
- can determine the best system configuration from antenna type, antenna orientation, and performance
- can perform an economic evaluation of RFID systems

2 Theoretical Background of UHF RFID

The abbreviation RFID stands for Radio Frequency Identification. RFID is part of the automatic identification procedures (Auto-ID). RFID technology has attracted increasing interest in the business environment by virtue of its ability to improve many industrial practices, mainly logistics, typically made with effective but inefficient technologies (Riemenschneider et al., 2007). The early literature on this subject area (Hardgrave et al., 2005; Riemenschneider et al., 2007) has proven that RFID brings four main advantages when compared with other identification technologies (e.g. barcodes and acousto-magnetic systems), namely: (i) the reader and tag do not need to be aligned for RFID readings (non-line of sight), (ii) it is possible to read a huge amount of tags in a short time frame, up to hundreds of readings per second, (iii) the data storing capacity of the tag, potentially provides more memory space than linear barcodes, (iv) it allows re-writing and managing the data written on the tag. In the following sections, the use of RFID in the industry is explained, the components of an RFID system are described, the communication between the reader and transponder is explained, and the factors influencing an RFID system are mentioned.

3 Use of RFID in Industry

In recent years, because of the increasing need for tracking and tracing products in supply chains, the use of RFID has increased. Large organizations such as Walmart and Tesco have been pushing their suppliers to tag products. In 2010, Walmart announced the decision to start using RFID technology to track such items as men's jeans and underwear. Today, RFID technology is used for all shipments and locations in the United States. More in general, studies on the fashion and apparel industry have proven that RFID adoption in environments using suitable platforms and standards can improve the whole supply chain (SC), for instance allowing coordination of players (Bindi *et al.*, 2016, 2018). Of course, such an approach also involves customers who have to share information suitable to SC coordination (i.e. customer demand). In this sense, Novotny *et al.* (2015) have proven the willingness of consumers to share information with SC via RFID, which eventually leads to providing better services to customers (Heim *et al.*, 2009). Fashion and apparel retailers especially have been driving the adoption of RFID for the last 10 years (Cilloni *et al.*, 2019). Among other advantages, an important focus of the fashion and apparel industry is on the existence of counterfeit products, which causes a huge amount of revenue

loss as high as 26.3 billion euros annually in Europe. RFID can be used to optimize store practices, also because the usefulness of the technology is well recognized by company staff, who are generally willing to use the technology in their tasks (Bertolini *et al.*, 2018). Still, the interest of the fashion and apparel retail sector is not limited to counterfeiting or the grey market: in 2016, Rizzi *et al.* (2016) identify 18 possible RFID use cases in this industry, further extended and used to realize an observatory of RFID adoption in the fashion and apparel industry (QR code to: <http://www.rfidlab.unipr.it/rfid-barometer/>), as well as to provide specific key performance indicators to improve retail and distribution practices (Bertolini *et al.*, 2017 ; Cilloni *et al.*, 2019).

Many other industries, however, have adopted RFID technology. Typically, RFID is adopted to improve logistics and SC flows (Baars *et al.*, 2009 ; Cao *et al.*, 2018; Gladysz & Santarek, 2015), as well as manufacturing operations (Cao *et al.*, 2017 ; Jiang & Cao, 2013 ; Ruppert *et al.*, 2018 ; Xiang *et al.*, 2017). Digital SC, leveraging RFID, can yield better and faster decisions, better visibility and quality of information, improved processes and productivity, reduced operating costs for logistics, and improved competitive positions (Attaran, 2020). RFID usage in this industry is estimated to grow from 3.6 billion in 2018 to 9.8 billion in 2025 (even though such forecasts do not always become reality).

The construction industry has been continuously interested in RFID adoption over the last 10 years. Its main applications relate to asset tracking and inventory management, and life cycle management of assets for buildings as well as infrastructures (Iacovidou *et al.*, 2018; Li *et al.*, 2020; Motamedi *et al.*, 2016 ; Prakash Chandar *et al.*, 2016 ; Valero *et al.*, 2015). Also, other important uses of RFID in the construction industry related to sharing information for controlling projects, and coordinating company departments and partners (Sun *et al.*, 2013), as well as tracking operators for the sake of their safety (Bugg *et al.*, 2018).

Beyond retail, manufacturing, and the construction industry, RFID has also gained attention in the past decade from service industries, mainly healthcare (Kereri & Adamtey, 2019). RFID has successfully been adopted for asset tracking and providing information to decision-makers about patients, hospital personnel, and hospital processes (Caredda *et al.*, 2016 ; Figueroa *et al.*, 2019; Ma & Yang, 2013 ; Manzoor, 2016). Other successful applications relate to (i) transportation, such as parking management and traffic surveillance (Nahian & Rana, 2020), (ii) tourism, such as enhancing museum expositions by providing additional information to operas (Handojo *et al.*, 2018), (iii) natural resources management, mainly to track assets (Keefe *et*

al., 2019), as well as (iv) academia to trace student attendance of courses and library operations (bin Mohd Nasir *et al.*, 2015).

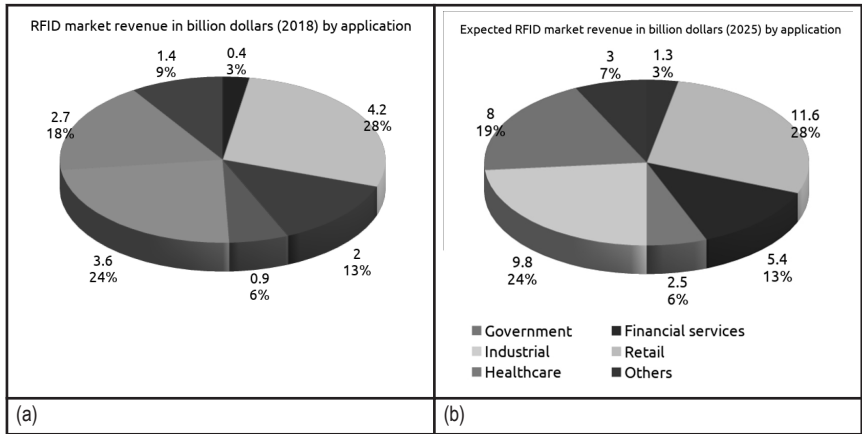

Figure 1: (a) market revenue of RFID adoptions in 2018, and (b) revenues forecasted for 2025. Data from www.statista.com²a_1.pdf

Finally, some considerations on the evolution of RFID applications. Previous research studies mostly focused on enhancing the security of radio frequency identification (RFID) protocols for various RFID applications that rely on a centralized database (Sidorov *et al.*, 2019). The reliability achieved has allowed researchers to enlarge the view of the big picture of the Internet of Things (IoT) (Da Xu *et al.*, 2014 ; Shammam & Zahary, 2019) and other related technologies, such as Wireless Sensor Networks (Landaluce *et al.*, 2020) and Blockchain (Ahamed *et al.*, 2020 ; Sidorov *et al.*, 2019 ; van Hoek, 2019). Surely increasing stress on security has to be applied for suitable trustworthiness of systems (Alotaibi, 2019 ; Ibrahim & Kamalrudin, 2018 ; Niraja & Rao, 2020).

2 Retrieved from: <https://www.statista.com/statistics/781314/global-rfid-technology-market-revenue-by-application/>. [Access available]. Last access: 2020.09.24

Components of an RFID System

An RFID system consists of a transponder, which is attached to the object to be identified, and a reader, with which this information can be read or written to the transponder, as shown in Figure 2.

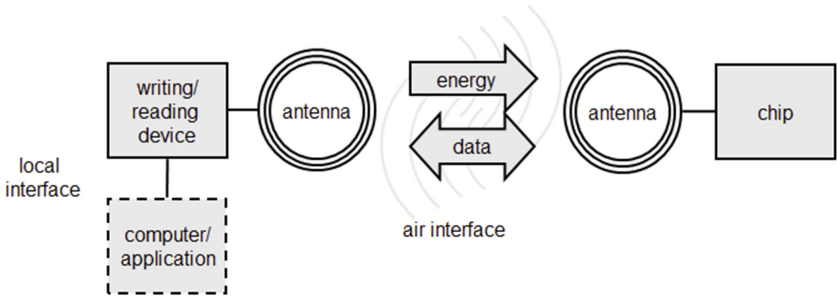

Figure 2: Components of an RFID System (Finkenzeller, 2010)

Transponder

The term transponder is a combination of “transmit” and “respond”. Quite often the term tag is used synonymously for transponders. The transponder has a microchip to process and store data and an antenna to communicate with the reader. Tags can be very compact, measuring only 0.05 x 0.05 mm, and thus are thin enough to be embedded in a sheet of paper. The antenna connected to the chip, however, is larger. Transponders are divided into active, semi-active, and passive types. The active ones have their own battery to power the microchip in the transponder and generate radio signals, and therefore these tags can achieve the greatest reading range. Semi-active tags have a battery to power the microchip, and passive tags use only the energy of the reader. Due to the absence of a battery, passive tags are the cheapest ones and are the most widely used; therefore, the focus of this chapter is also on passive tags. The electrical current induced in the antenna by an electromagnetic signal from the reader provides sufficient power for the CMOS (an acronym for complementary metal-oxide semiconductor) silicon chip located in the tag to operate and transmit a response signal. Therefore, the chip’s low sensitivity threshold level is important for high reading ranges. The read sensitivity of an Impinj Monza R6 chip is as low as -22.6 dBm, while the write sensitivity is at -18.8 dBm. In order to write data to an RFID tag, a closer distance is required.

Readers

There are different types of readers, classified on the basis of their characteristics. As far as the tag typology (active/passive) to read is concerned, readers for active tags are different from readers for passive tags. The main difference relates to the need for coping with severe standards on RF signals and, hence, passive tags are strictly normed. For instance, passive tags' signals working at UHF are normed by the standard ISO/IEC 18000 Type C (otherwise known as EPC Gen2, Class 1), in terms of modulation method, as well as bandwidth and the frequency range emitted. Of course, signals 'activating' passive tags come from the readers, and thus radio frequency (RF) signals of readers are normed. As regards reader typology, three main typologies exist:

Portals: items pass through antennas equipped on fixed structures

Handheld (mobile) readers: similar to remote controllers or scanners for barcodes

Fixed readers: small devices fixed in specific positions of facilities or buildings

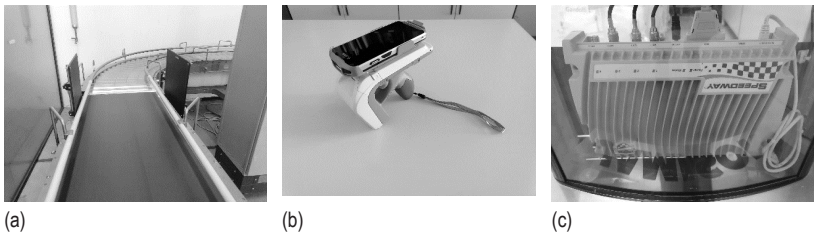

Figure 3: (a) Near Field/Short Range UHF Antenna—A1030 Times-7 Gateway, (b) Zebra RFD8500 RFID (UHF) Mobile Reader, (c) Impinj IPJ-R1000-AS11M3 RFID Reader

Antennas

One of the main components of a reading system (the same applies to a tag) is one or more antennas. Antenna layouts differ and their usage depends on the type of application. An antenna is linked to an important value, the antenna gain G , indicating 'the factor by which the radiation density S is greater than that of an isotropic emitter at the same transmission power' (Finkenzeller, 2010, p. 117), which is shown in Figure 4 using the example of a dipole. Short-range readings require antennas with a negative antenna gain to limit the signal output of the reader. While medium- and high-range

applications require antennas with a positive gain to amplify the reader output.

Electromagnetic interference needs to be considered when designing antennas (e.g. eddy currents, signal fading) and their entity depends on the frequency range. For a more in-depth analysis, please refer to Dalla Chiara (2011), Souryal et al. (2010), and Ying et al. (2009). RF signals (waves) pass through many solid materials (though their strength will be reduced due to absorption). Therefore, they cannot be easily contained within the desired space, nor can we ignore the effects of radio signals transmitted by devices located a long distance, even thousands of feet away.

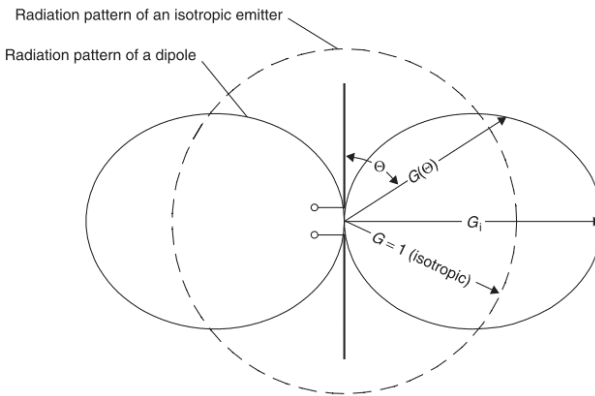

Figure 4: Radiation pattern of an isotropic emitter and dipole (Finkenzeller 2010, RFID handbook, p. 117)

RFID Frequency Ranges and their Characteristics

Various frequency ranges can be used for data transmission via RFID, which are dependent on country-specific laws and regulations. Depending on the frequency range used, the technological characteristics and thus the possible applications of RFID systems vary. Basically, the RFID frequencies are divided into the ranges Low Frequency (LF), High Frequency (HF), Ultra High Frequency (UHF), and Microwave (MW)³. The table below shows the typical working frequencies, the read range, the type of coupling, the

3 (Bundesnetzagentur, RFID, das kontaktlose Informationssystem, p. 3)

reading speed, and examples of applications. Since this chapter deals with RFID in logistics, the focus is on the UHF frequency range.

Table 1: Frequency ranges and their characteristics⁴

	Low Frequency (LF)	High Frequency (HF)	Ultra-High Frequency (UHF)	Microwave (MW)
Working frequencies	125–135 kHz	6.78 MHz 13.56 MHz 27.125 MHz 40.680 MHz	433.92 MHz 868 MHz (EU) 915 (USA)	2.45 GHz, 5.8 GHz
Read range	Up to 1m	Up to 3m	Up to 9m	> 10m
Type of coupling	inductive	inductive	electromagnetic	electromagnetic
Reading speed	slow	slow to medium	fast	very fast
Examples of application	animal identification	access control, time recording, theft protection	warehouse, logistics	vehicle identification

As far as the worldwide principles of RFID are concerned, there are two main reasons to adopt the corresponding regulations. RF signals (waves) travel almost forever, pass through many solid materials, and cannot be easily held within the desired space. Radio devices can interfere with your RF system, and your system can interfere with them. These types of interference affect the performance of an RF system, i.e. can reduce the read range of a system or render it inoperable. The second reason to control RF transmission is to avoid injuries to humans and animals. RF devices operating at 2.4 GHz range and higher can seriously damage human tissue. A regulation must be established as to the level of safe exposure, and some mechanism has to be created to certify and monitor compliance. In Europe, UHF RFID systems are assigned a frequency range of 865 to 868 MHz and a 2 W max power. As a result, a tag designed for the US will have problems being read in Europe and vice versa, since in the USA frequency range is assigned between 902 and 903 MHz, while max power is normed at 4 W. To overcome these problems, RFID systems must be designed to incorporate all the frequency ranges (within the UHF band) used all over the world. This has been accomplished by EPCglobal Gen-2 and ISO 18000-6C standards. Readers and tags designed according to these standards will interoperate anywhere in the world.

4 (Bundesnetzagentur, RFID, das kontaktlose Informationssystem p. 5), (RFID, Tamm und Tribowski 2010, pp. 18–19)

Backscatter Communication

For data transmission in the UHF range with passive tags, the backscatter method is used. The RFID reader generates an electromagnetic (EM) field with which it supplies the transponders located in the reader's reading field with energy and activates them. The RFID reader sends its data to the transponder via electromagnetic waves. The transponder reflects these electromagnetic waves to send its data to the reader. By means of a load resistor, the transponder can modulate its data and the reader interprets the backscatter signal received. If the object that the electromagnetic waves hit, here the tag antenna, is in resonance with the waves, then the backscatter will be especially good.

Near and Far Field Regions of Antennas

Since the basis for transmission in this respect are electromagnetic fields, the near and far field regions of antennas are discussed here. The electromagnetic field characteristics vary as a function of distance from the antenna. They are broadly divided into two regions, the near-field region, and the far-field region.

Table 2: Overview of near and far field

Near field radius $\ll \lambda/2\pi$

nature of waves depends on source characteristics
high current, low voltage, the source is mainly magnetic
low impedance

Far field radius $\gg \lambda/2\pi$

nature of the wave depends on the propagation medium
electric and magnetic fields are both planar waves

Near-field region antennas

A distance less than $\lambda/2\pi$ (λ - wavelength of the EM waves) between a standard UHF patch antenna (antenna with one emitter) and an RFID tag is called near field (see Figure 5), and there are specialized near field antennas. Near-field antennas solve the problem of using tags in difficult climatic and operating conditions and in hard-to-reach places. At the same time, they are compact and powerful. When we are determining the registration distance between the tag and the near field antenna, the size of the loop (the antenna pattern is depicted in the form of a loop) that is created by the emitter is important. By adjusting this parameter, the near field antenna is able to read UHF tags from a distance of 1 cm or less, since at a smaller distance the

signal from the tag is not shielded by the near field of the antenna and the influence of magnetic or dielectric permittivity is excluded.

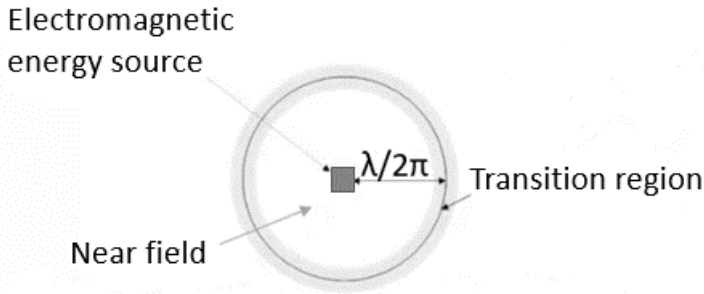

Figure 5: Near field

Far-field region antennas

Far-field antennas are used to create registration zones for UHF tags up to 15 meters and are used at the entrances to the warehouse and production facilities when assembling RFID gates, portals, or frames on a conveyor. Far-field antennas have a pronounced directivity, and the readout range of such antennas depends on gain and polarization. Despite the fact that RFID antennas are not the main device in the RFID system, the correct operation of the whole system depends on their performance and correctly chosen settings. One condition that must be met when conducting measurements in the far-field region is that the distance from the antenna must be much greater than the size of the antenna and the wavelength.

Antenna Polarization

RFID antennas polarization is one of the crucial parameters for setting up an RFID system. The communication is based on electromagnetic waves, which travel in two manners: linearly polarized (vertically or horizontally) or circularly polarized (see Figure 6). When EM waves propagate in a single plane either horizontal or vertical, it is called linear propagation. And when EM waves propagate in a manner where the amplitude of the waves is constant but rotates with time, it is called circular polarization. The orientation of the antennas for both the tag and the external device should be such that both antennas have the same polarization. Linearly polarized antennas should be used when the tag antenna orientation is known and does not

change over time. However, if the tag antenna orientation is unknown or changing, circularly polarized antennas should be used, as the tag antenna orientation has less impact on the reading results. However, circularly polarized antennas reduce the power transmitted (for details, see the next subsection) when compared to linearly polarized antennas, which may be compensated for by the antenna gain and higher power output settings in the reader. Also, the reader and tags can be placed on different planes and at different heights. In the use case in Chapter 2, right-hand circularly polarized (RHCP) antennas are used.

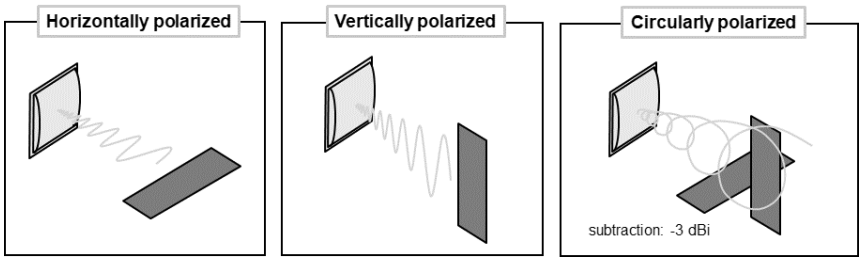

Figure 6: Antenna polarization

Power Emitted at the Antenna

Not only does polarization have an influence on the communication, but so does the power emitted at the antenna because it affects the reading range. Calculating the emitted power at the antenna is necessary, as conformity to the maximum allowed the power of 2 Watts of effective radiated power (ERP) according to European regulations needs to be ensured. ERP values are based on half-wave dipoles, while American regulations use effective isotropic radiated power (EIRP) based on isotropic antennas. 4 W (EIRP) equal 3.28 W (ERP) or 35.15 dBm. New regulations in Europe will allow 4 W (ERP) in a different frequency range. However, using the upper band frequency ranges (915–921 MHz) is not yet allowed in all member states (e.g. Germany). Details are reported in Table 3.

Table 3: Measurement reference and characteristics

	Measurement Reference	Standardization body	Max Radiated Power Allowed	Antenna Gain Reference Value	Frequency range
ERP	Effective Radiated Power	ETSI (Europe, Lower Band)	2W (33dBm)	dBd	865–868 MHz
		ETSI (Europe, Upper Band)	4W (36dBm)	dBd	915–921 MHz
EIRP	Effective Isotropic Radiated Power	FCC (US)	4W (36dBm)	dBi	902–928 MHz

The power settings in the reader are given in milliwatts (mW) or decibels in relation to a milliwatt (dBm). Watts can be converted to dBm using the following formula:

$$P(\text{dBm}) = 10 \times \log_{10}(P(\text{W})) + 30$$

The power is increased by the antenna gain and reduced by the cable loss between them. The loss of the connectors is low and usually ignored in power setting calculations. The cable loss depends on the frequency, the quality of the cable, and its length. If a circularly polarized antenna is used, the signal strength is reduced by 3 dBi (decibels in relation to an isotropic antenna). Antenna gains are often given in dBi, dBic (decibel isotropic circularly polarized), or dBd (decibel dipole). The units dBi, dBic, and dBd can be treated just like dB, because they quantify the gain of an antenna relative to a corresponding antenna with a gain of 1 (0 dB) and they can be added to or subtracted from dBm values for power calculations. The following conversions apply:

$$\text{dBd} = \text{dBi} - 2.15\text{dB} = \text{dBic} - 5.15\text{dB}$$

According to ETSI EN 302 208, the calculation of the radiated power in dBm for a circularly polarized antenna is calculated as follows:

$$P_{\text{ERP}} = P_{\text{C}} + G_{\text{IC}} - 5.15\text{dB} - C_{\text{L}}$$

Where

G_{IC} = antenna gain of a circular antenna in dBic

C_{L} = total cable loss in dB

5.15 = 3 dBi loss for the circularly polarized antenna plus 2.15dBm to convert dBi to dBd

Example calculation of the radiated signal power for a reader with a power setting of $P_{\text{C}} = 1000\text{mW}$ (30dBm), antenna with 5dBic (thus circularly polarized), and a cable loss of 1.5dB:

ERP calculation = 30 dBm + (5dBic -3dB) - 2.15dB - 1.5dB = 28,35dBm (684mW)

EIRP calculation = 30 dBm + (5dBic-3dB) - 1.5dB = 30,5 dBm (1.125W)

Table 4: Data settings for the Use Case

Power settings reader	Far-field antenna
Antenna gain	15–30 dBm (0.03-2W)
Cable loss	7 dBic
Antenna type (circular) and dBd/dBi conversion	1.5 dBm
Possible output at the antenna	5.15 dB
	low: $15 + 7 - 5.15 - 1.5 = 15.35$ dBm
	high: $30 + 7 - 5.15 - 1.5 = 33.35$ dBm
Maximal allowed emitted Power according to European regulations	2 Watts (ERP, lower band)
	4 Watts (ERP, higher band)

Table 4 shows the data for the settings in the given use cases, focusing on far-field antennas.

Received Signal Strength Indication (RSSI)

As already mentioned, the electromagnetic signals emitted by the reader are reflected by the transponder. To indicate the signal strength of the back-scattered tag signal, the Received Signal Strength Indication (RSSI) is used. RFID readers provide RSSI values when reading RFID tags. A higher RSSI value is interpreted as a better connection and as more reliable communication. The RSSI decreases with a greater distance between the tag and reader; thus, it has also been used for locating tags in an RFID read zone. However, the RSSI is also affected by absorption, reflections, frequency, and relative tag orientation (angle and height difference) to the reader antenna. If the tag moves closer to a reader antenna, the RSSI increases, and it declines if the tag moves further away from the antenna. RSSI values may differ between readers from different manufacturers. Additionally, the gain of the reader antenna and cable loss influences the values measured. Thus, a comparison of RSSI values should be made with the same reader and antenna setup.

Modulation and Encoding

In the communication between the reader and tag, the transmission rate, method of modulation, and coding/encoding are important parameters for transmission, which are described below:

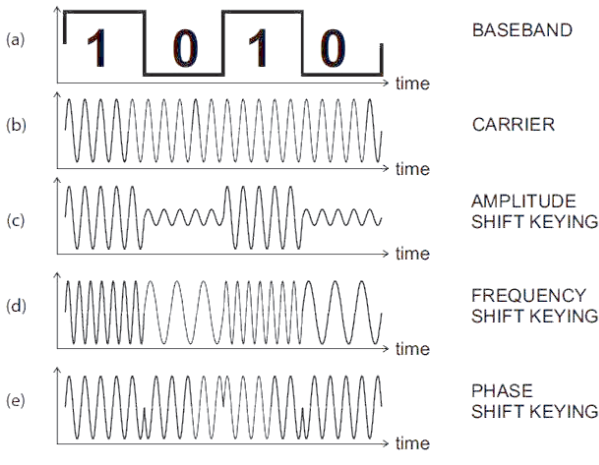

Figure 7: Methods of modulation (Kaur & Kaur, 2015)

Transmission rate

Baud rate of a data communications system is the number of symbols transferred per second. A symbol may have more than two states, so it may represent more than one binary bit.

Bit rate dimension for the efficiency of data transmission is an indication of the correct number of bits transmitted per second.

Methods of modulation

Amplitude modulation: Amplitude Shift Keying (ASK) is an easy technical application that does not need high bandwidth but is interference prone.

Frequency Shift Keying (FSK) needs a higher bandwidth, for example: communication by telephone.

Phase Shift Keying (PSK): complex demodulation, almost fail-safe.

According to the standard EPCglobal UHF Class 1 Gen 2, for the reader-to-tag link the modulations ASK, FSK, and PSK can be used, and for the tag-to-reader link, the modulations ASK or PSK can be used.

Methods of coding

Figure 8 shows the different methods of coding.

NRZ-L (non-return to zero level) coding
 uses the absolute voltage level for coding
 fixed signal level during an interval
 signal changeover at the bounds of an interval
 possibly problems in detecting the clock
 example: standard in digital devices (PC, ...)

Manchester coding

using a change in voltage in the middle of an interval
 bit 1 = change in voltage in one direction (direction is freely definable)
 bit 0 = change in voltage in the other direction, good detection of the clock

example: IEEE 802.3 (Ethernet, low-high = 1, high-low = 0, *not corresponding to the figure below*)

FM0 coding

using a change in voltage at every boundary of an interval
 bit 1 = no change in voltage in the middle of an interval
 bit 0 = change in voltage in the middle of an interval

example: EPC Class 1 Gen 2 (Tag to Reader), optional Miller
 Miller coding

no change in voltage at every boundary of an interval
 bit 1 = change in voltage in the middle of an interval
 bit 0 = no change in voltage

pulsing is a problem, but good data transmission rates

example: EPC Class 1 Gen 2 (Tag to Reader), optional FM0

Pulse Interval Encoding (PIE)

Tari = reference time for '0' (6,35 μ s – 25 μ s)

time for '1' = 1,5 to 2 * Tari

example: EPC Class 1 Gen 2 (Reader to Tag)

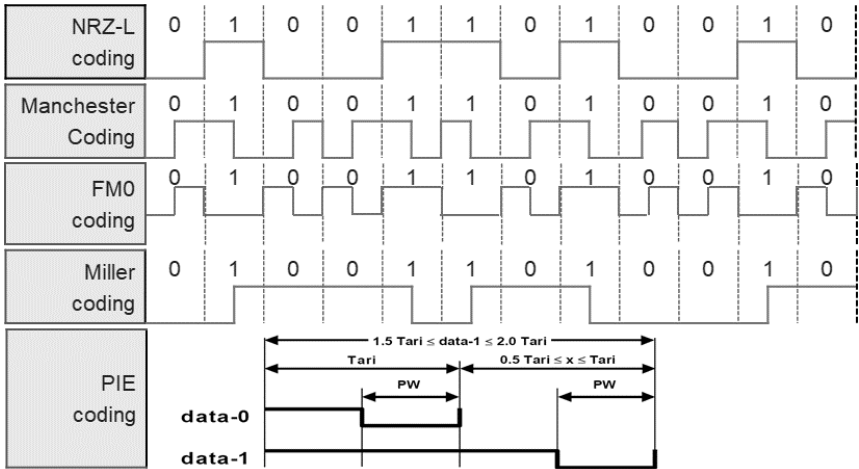

Figure 8: Methods of coding (Source: Rizzi et al., 2011)

Anti-collision Methods

If several tags are in the reading field of one RFID reader and simultaneously send data to it, collisions will occur, and the reader will not be able to identify the single tags. To avoid these collisions, anti-collision methods are used. Table 5 shows the two basic anti-collision methods: Query tree and Slotted Aloha.

Table 5: Methods of anti-collision

Methods used to avoid collisions of transponder signals	
<p>Query tree</p> <ul style="list-style-type: none"> the transponder ID uses a scheme according to ISO 15693 the Tag-ID is queried starting from its end digit until each tag can be uniquely distinguished 	<p>Slotted aloha</p> <p>EPC Class1 Gen2 standard the reader assigns random numbers to the tag until each tag has been uniquely identified the amount of available random numbers (2^Q) is based on the Q-value, which can be assigned to or may be automatically chosen by the reader if the number of tags to be read is known, assigning an appropriate Q-value can increase the performance</p>

Data on the Transponder

After the anti-collision has been successful, the reader can read or write data to the tag. Each tag has a transponder identification number (TID), which is written onto the tag by the chip manufacturer. Well-known manufacturers are Impinj, NXP, and STMicroelectronics. They provide chips with different memory capacities and functionalities (see Table 6). Passive tags can contain rewritable non-volatile EEPROM-type memory.

Table 6: Memory capacities and functionalities

Manufacturer	Chip Type	TID	Ull	User Memory
Impinj	Monza 4QT	32/96 bit	128 bit	512 bit
	Monza 4E		496 bit	128 bit
	Monza 4D		128 bit	32 bit
	Monza 5		128 bit	-
	Monza R6		96 bit	-
	Monza X-2K		128 bit	2176 bit
	Monza X-8K			8192 bit
NXP	G2XL	64 bit	240 bit	0 bit
	G2XM	64 bit	240 bit	512 bit
STMicro-electronics	XRAG2	64 bit	176 bit	128 bit
		64 bit	304 bit	0 bit
		64 bit		

The chip, which constitutes the intelligence of the tag, contains the power supply and signal transmission stage (by modulating antenna impedance), the control logic, and the memory. The memory of an ISO/IEC 18000-6c tag is divided into four memory banks, of which three are always present, and an optional one, which is present only on tags equipped with an EEPROM type user memory. The first three banks are used to contain the EPC (Electronic Product Code) numbering, the passwords to lock and kill the tag, and the information of the tag producer, while the fourth bank, the optional one, is intended for possible further user memory. The TID (Tag ID) is a unique code relating to the chip and the manufacturer that can only be read, as it is written in ROM (Read Only Memory) during the chip manufacturing process. Some manufacturers, in addition to their own unique company code, also report a unique serial identifier of the single chip produced in this bank. The EPC is a globally unique identifier that is designed to allow the automatic identification of objects. It contains an identification number for the product manufacturer, the product, and

a unique serial ID. However, as the EPC is provided by GS1, the main field of application is retail applications. This memory space, however, can alternatively be used to store unique identifiers based on ISO standards. The technology provides for assigning a unique identifier to each product according to the 'license plate principle'.

Table 7: Memory banks

Memory bank	Functions	Comments
bank 00	'kill' password	each 32 bit
	'access' password	
bank 01	Cyclic Redundancy Check (CRC-16)	check sum method
	Protocol Control	incl. length of the EPC; numbering pattern (e.g. application family identifier / ISO 15961)
	Electronic Product Code (EPC)	ID assigned by the product manufacturer according to GS1 or ISO standards
bank 10	Tag Identification	ID assigned by the chip manufacturer (cf. ISO 15963)
bank 11	User memory	optional free memory

Desired and unwanted readings

Errors in the data collected can diminish the advantages of using RFID or even increase costs as compared to not using RFID systems. The two major origins of data collection errors are: (i) false positives, i.e. reading a tag that is unexpected or unwanted, also called ghost tags, and (ii) false negatives, i.e. missing the read of an expected RFID tag. A false negative result in no collected data: the identifier stored on the tag is not collected by the reader. A false positive result in wrong data: specifically it is read and reported by the identifier of a tag attached to a product that is not the object of the analysis but is within the reader's field. Both forms of erroneous data collection can have a significant impact on the benefits of using RFID systems; therefore, they must both be minimized (Engels, 2005).

Alpha and Beta Errors

Alpha and Beta errors are two concepts adapted from statistical hypotheses testing that can be used as indicators of the reliability of the RFID system. We can therefore adapt α and β errors to an RFID system. Error α , or type I error, is the rejection of a true null hypothesis, i.e. a false negative or not rea-

ding expected tags. In contrast, error β or type II error is the non-rejection of a false null hypothesis, i.e. a false positive or reading unwanted tags.

Alpha Error

The Alpha error indicates the reliability of the system. Indeed, having a list of tags that pass through an RFID gate, the Alpha error represents how many tags that should be read have not been read. It can be represented with the following formula:

$$\text{error } \alpha = \text{no. of expected tags not read} / \text{total no. of expected tags}$$

This concept of reliability must be integrated into the minimum lifecycle of a tag. Indeed, it is required that a tag guarantees at least 100,000 reading/writing cycles without damage. In this lifecycle, it has to attest to reading reliability of 99.99%, which can be translated into one missing read each 10,000th reading cycle, which equals an Alpha error of 0.01%. Also, accuracy of 99.998% is required, which can also be read as no more than two wrong lectures for every 100,000 readings.

Beta Error

The Beta error indicates the noise of the system. In fact, it is useful to calculate how the other tags in the environment are read even if the focus should not be on them. Actually, it indicates how many tags that must not be read have been read during the measuring. It can be summarized in the formula:

$$\text{error } \beta = \text{no. of unexpected tags read} / \text{total no. of unexpected tags}$$

Both Alpha and Beta errors are directly influenced by the type and orientation of the antennas, their power level, and the distance between the antennas and the tag. The objective is to minimize the two errors. However, they react in different ways to the variables. Indeed, having a higher power level, the Alpha error will be reduced, but it will be more possible to read unwanted tags. Moreover, having desired products closer to the antennas, and distancing the unwanted ones, the Alpha error will decrease in accordance with the first solution, while the Beta error will decrease due to the second.

Factors in Performance Limitations and Testing

The relevant factors defined by the regulations that affect performance, in terms of read rate and range, can be referred to as (Rizzi *et al.*, 2011) (i) the reading system (frequency and transmission power, antenna gain and

polarization, receiver sensitivity, modulation characteristics), (ii) the tag (activation energy, antenna gain and polarization, modulation characteristics), (iii) the material onto which the tag is applied (paper, wood, glass, plastic, metal, see also HFT chapter on tag measurement), and (iv) the external environment (reflective or absorbent surfaces for radio frequency, presence of water in the form of moisture, condensation or ice, chemical materials, electrical or RF noise).

Tests are carried out to determine the influencing factors in an RFID system and determine the best system configuration.

However, despite the standard ISO/IEC TR 18046 describing in detail the test conditions for the RFID tags, the operating conditions of industrial logistics, which is a particularly attractive area for passive UHF RFID technology, are very different from the test conditions described in the standard. It is therefore useful to move from a standard and standardized approach to a more pragmatic one, which is close to typical logistics situations, in order to qualitatively and quantitatively assess the performance of RFID systems in such scenarios.

The following are some results related to the execution of tests to investigate the behaviour of RFID technology in the presence of commercial products. In order to have a complete vision of the performance of the technology applied to real products, it was decided to perform a testing protocol with products with different characteristics, in compliance with the guidelines presented in the standard ISO/IEC TR 18046.

From the results of reading tests under static conditions, it can be seen that reading performance is strongly influenced by (i) the presence of metal in the primary packaging (coffee, milk in a carton, oil in tin), (ii) a product containing water (milk, fruit juice), (iii) the position of the tag on the box for products containing metal or water. In particular, it is possible to identify a position for which performance is maximized, a position that allows you to distance the tag from the metal surface of the package or the product containing water. It has to be underlined that in an industrial environment, where products pass through the RFID gate on a conveyor belt, if the speed of passage under the gate increases, performance tends to decrease in terms of instalments and, sometimes, accuracy.

The results obtained do not have an absolute value, because if the boundary conditions change, the performance could be substantially different.

Material to which the transponder is attached

The material to which the transponder is attached has a significant influence on the performance of an RFID system in terms of reading range and detection rate.

A large amount of research on the topic shows that care must be taken when RFID interference is present in an RFID operation. Covering materials of products can be categorized into two groups based on their interference in RFID operation: (i) those that have no effect on the operation, i.e. polyethylene stretch wrap and corrugated boards; (ii) and those that have an effect on the operation, i.e. aluminium surfaces, glass. However, this does not mean that the materials from the second group cannot be used in RFID operations. Typical substrates are metal, glass, and polyethylene.

1. **Metal**, common packaging material in the food and beverage industry, has a very large impact on the transmission of radio frequency. Metal does not allow radio frequency to pass through it. It also changes the inductance of antennas (on both reader and tag) and retunes its resonance frequency. In UHF, this may increase the read range of an RFID system if enough air gaps between the metal and tag are provided. There is some data reported that a metallic substance in front of the tag reduces the RFID system's operating range by 30–50%. The effect of metal behind the tag depends on the distance between the tag and the metal. A distance between 3–6 cm (or more) will minimize the effect of a metallic substance behind the tag. Another possibility is to use special On-Metal tags designed for this material.
 - a) **Glass** is an inert and high barrier packaging material and is used extensively in primary packages. Glass can cause the resonance frequency to be detuned (VDA 5500).
 - b) **Polyethylene (PE)** is a commonly used pallet stretch wrap material. The impact of stretch wrap on radio frequency is very important to pallet level tracking. It is important to know beforehand if the stretch wrap material will interfere with the pallet's readability. This will determine if the pallet tag needs to be placed on the outside of the stretch wrap or if it can be placed under the stretch wrap. In terms of pallet load tracking, the tags can be placed under PE stretch wrap without it interfering with an RFID operation. Placement of the tag under pallet stretch wrap is more desirable in order to prevent tags from being damaged, lost, or stolen during shipping/handling.

Besides these three materials, there are others that influence RF signals. Table 8 shows an overview of some materials and their effects.

Table 8: Materials and their effects on RF signals

Materials	Effects on RF signals
Cardboard	<ul style="list-style-type: none"> • Absorption (humidity) • Detuning (dielectric)
Conductive liquids (shampoo)	<ol style="list-style-type: none"> a) Absorption b) A (tiny) layer of salt water (1mm or more) block tag emission
Plastic	<ul style="list-style-type: none"> • Detuning (dielectric)
Metals	<ol style="list-style-type: none"> 1. Reflection
Group of aluminium cans	<ol style="list-style-type: none"> a) Complex effect (slow, filter) b) Reflection
Human or animal body	<ul style="list-style-type: none"> • Absorption • Detuning (dielectric) • Reflection
Aluminium foil (27 μm or more)	<ul style="list-style-type: none"> • Blocks tag emission

Noise and interference

The main interference relates to operations carried out with other radio communication devices and applications (Talone & Russo, 2006): this aspect is regulated by norms about frequency ranges and bandwidth at both an international (International Telecommunications Union) and a European level (European Conference of Postal and Telecommunications Administrations). Furthermore, interference also occurs because of other sources working at the same frequency and bandwidth. For instance, Zhang et al. (2013) have analyzed how to solve interference between two or more readers working concurrently. Their study has proven that interference is higher in powerfully noisy environments. It is important to mention that noise is different from interference, since interference is generated by other signals, whereas noise is everything that is not a useful signal and can thus occur due to uncontrolled parameters, such as temperature as well as moon phases⁵. As a result, noise has to be considered and taken under control, but it is not possible to avoid it. A different approach is needed for interference with an electrostatic charge: the focus is on the protection of RFID tags more than avoiding bias (Blitshteyn, 2005), and lots of patents do exist to

5 Source: [https://eng.libretexts.org/Bookshelves/Electrical_Engineering/Book%3A_Electrical_Engineering_\(Johnson\)/06%3A_Information_Communication/6.08%3A_Noise_and_Interference](https://eng.libretexts.org/Bookshelves/Electrical_Engineering/Book%3A_Electrical_Engineering_(Johnson)/06%3A_Information_Communication/6.08%3A_Noise_and_Interference). Available for access. Last access: 2020.09.29

address this issue⁶. If the basic nature of interference is electromagnetic (radio communication signals as well as electric signals), nonetheless the buildings and other elements located in the environment in which reading operations are performed can affect the readings themselves. For instance, Holland et al. (2011) have discussed artificial neural network algorithms for device localization by means of RFID, overcoming interference from metal (i) walls and (ii) structural elements, as well as human presence. More in general, studies have proved that (i) correctly setting the layout of readers, (ii) tagging the items to be identified in a suitable manner, as well as (iii) preferring passive tags to active ones can ease this kind of interference to the extent that readability is not affected (Kolarovszki, 2014 ; Kolarovszki et al., 2016).

4 Use Case

In this section, the use case and the practical exercises are explained.

George is a supply-chain-management consultant working for a renowned food and beverages company. He has been requested to manage a pilot project to implement automated identification (Auto-ID) on one production line of the company that produces cases of different food and beverage products. George decides to use Radio-Frequency Identification (RFID) to improve inventory accuracy in its warehouse because with RFID no line of sight is needed, hundreds of readings per second are possible, and the RFID tags can be used in other areas of the supply chain. George heard of several examples of RFID implementation that significantly improved inventory accuracy at a recent exhibition. However, he wants to test the usability of the RFID system in a realistic scenario, before suggesting the solution to his client. He is especially interested to see how metallic cans and bottles with liquids can cause problems in the identification process. The simple RFID system George is planning to test is composed of one reader and two antennas, tagged product cases, and a system with which to gather and transmit data (as shown in Figure 9). To relieve his burden, George decides to entrust the RFID testing to a group of four students working in part-time positions. He asks the students to report the findings in a management report so that George can forward the results to his customers and take an informed decision about the further rollout of the RFID solution.

6 Source: Google patents. An example of query: 'RFID electrostatics discharge protection'. Results: 6,100 on 2020.09.29

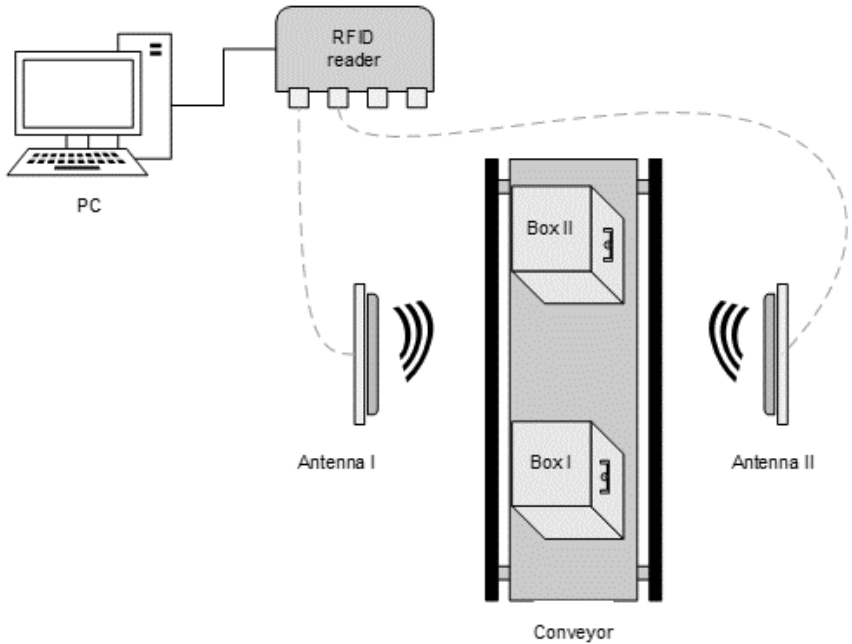

Figure 9: Example of an RFID system

Creation of an RSSI curve

After they had seen the past project, the first part they wanted to test was the reaction of the RSSI curve related to the product analyzed and the power level set. Indeed, they decided to follow the experience studied but applied a scaffolding approach. They started with two different power levels (18 dBm and 30 dBm), one type of antenna, and just an empty box, with a single Dogbone R6 Monza, applied horizontally on its side, in order to analyze the trend of the RSSI curve when the radio frequency does not have interference. This trend has to be analyzed according to the function of the RSSI and the reading time.

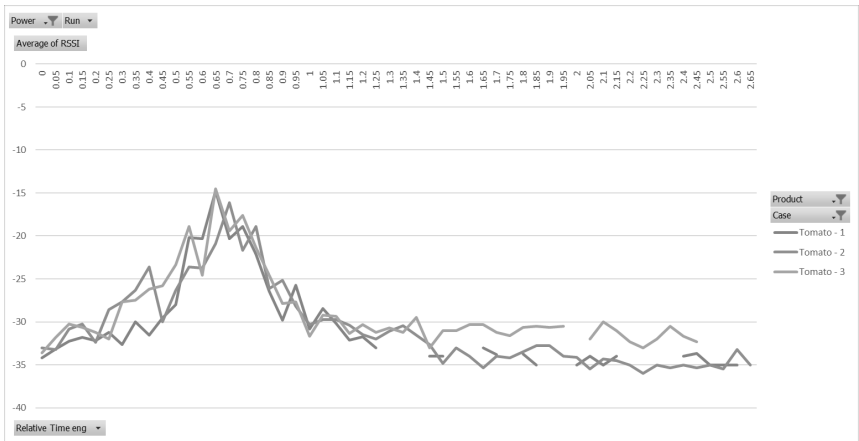

Figure 10: Example of a real RSSI Curve

Successively through these basic tests, they saw that with a low power level (18 dBm) the curve is volatile, while with a higher power level (30 dBm), the RSSI curve became continuous but consisted of a huge amount of unwanted tag readings (those that were present in a laboratory, but were not attached to the products studied, but were registered). After receiving these results, the students decide to extend the power settings to five levels (18, 21, 24, 27, 30 dBm), analyze their trend with far-field and near-field antennas, and analyze the empty boxes and three more products to see how the RSSI curve tendency changed.

As the company where George works specializes in the food industry, the products analyzed are (i) plastic water bottles, (ii) tomato sauce metal cans, and (iii) plastic cooking oil bottles. Moreover, the following products were chosen due to their nature and packaging peculiarities, as they represent (i) an RF absorbing product, (ii) an RF reflecting product, and (iii) an RF friendly product. As the empty box, each box studied was equipped with a single Dogbone R6 Monza tag on the side. In order to receive faster reports from the students, George decided to assign each group of students a different product.

Once all the students had finished their own analyses, George gathered all the results and created a final report by merging them with the previous analysis and comparing them.

Tasks: Creation of RSSI curves

- a) Create an RSSI Curve with the power levels 18, 21, 24, 27, 30 dBm and with the products (i) plastic water bottles, (ii) tomato sauce metal cans, and (iii) plastic cooking oil bottles
- b) Analyze RSSI Curve performance according to different power levels
- c) Analyze RSSI Curve performance according to a different type of products

Reading optimization

After receiving the report, George understood that the RSSI trend shows the reaction of different products but there is a lack of reliability in the RFID system. To measure it, George decided to analyze the Alpha and Beta errors which are the percentage of tags missed in the readings, and the percentage of unwanted tag reads respectfully. As previously, George and his students, started the investigation of former projects and experiences.

By studying this project, George and the students understood that the efficiency of the system lies in the function of different parameters like: (i) type of antenna, (ii) orientation of antennas, and (iii) power level. Similarly to the previous analysis, the students start with a simplified experiment, having three different power level parameters (18, 21, 24 dBm), one type of antenna (Far Field), one orientation (parallel to the conveyor), and one product (metal cans of tomato sauce). To perform the experiment, George and the students placed three boxes of the same product on a conveyor belt. Each lateral side of each box contained two tags of the same type, but a different orientation: one vertically and another one horizontally oriented. The tags amounted to eight tags per box and 24 per three boxes, which are present in the experiment. They wanted to investigate the corresponding errors in relation to each box, by considering the tags on that box as the only desired tags.

After collecting and analyzing the data, the students submit the report to George. However, George finds the results inconclusive and is convinced that testing five different power levels is not enough to determine the best system configuration. Thus, George decides to reduce a step in the power levels to 1 dBm and analyze each power level from 18 dBm to 30 dBm. Moreover, he is eager to know more about possible improvements through antenna modifications. Firstly, he wants to know how changing an angle in the far-field antennas to the disposition of a tag influences the reading results. Secondly, he has heard that specialized near-field antennas may show

better results in the current testing scenario with only ~70cm between both antennas. He chooses to compare the following different antenna setups:

1. Near-field antennas in parallel orientation (NF)
2. Far-field antennas in parallel orientation (FF //)
3. Far-field antennas rotated 45° in motion direction (FF + 45°)
4. Far-field antennas rotated 45° against motion direction (FF - 45°)

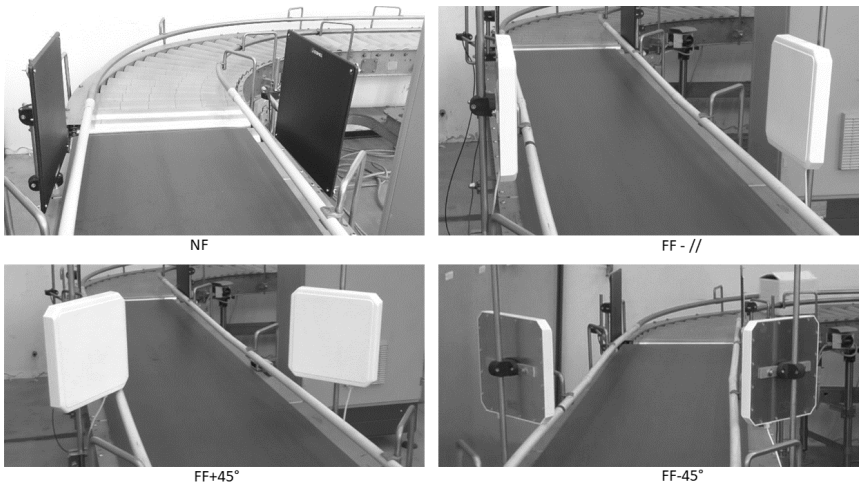

Figure 11: Scenario 2 antenna configurations.

To do so, George assigned testing the different antenna setups to four different students.

Once the experiments were completed, the students created a report with the conclusions on the Alpha and Beta errors' trends according to the different power levels. To compare the results, George gathered all the Alpha and Beta errors from the different configurations, analyzed them again and added them to the management report. In the report, the differences between the different configurations and how the desired and unwanted readings behave accordingly are highlighted.

Tasks: Reading Optimizations

- d) Measure and calculate Alpha and Beta errors in relation to the different boxes, power levels (18 to 30 dBm), different antennas (near and far

- field), different orientations (parallel, 45° in motion and 45° against motion direction) and RSSI
- e) Compare the results achieved with the different antennas' configurations and comment on them
 - f) Select the most effective combination of type of antenna, antenna orientation, and power level

Economic evaluation

On receiving the report, George immediately decided to work on the missing economic considerations himself. In detail, George's aim is that of calculating the most remunerative value of reading power of the RFID gates, based on economic values and estimations. At present, the company produces on average 300,000 cases of products per year.

First, George identified the following (unitary) costs per element of the RFID system installed in the production line:

Element	Cost [€/u]
Tag	€ 0.12
Antenna	€ 300.00
Reader	€1,200.00
Printer	€ 4,000.00

Also, the following boundary conditions are provided for the products:

- Each printer can process 100,000 tags/year,
- Each conveyor line is provided with a reading gate, composed of one reader and two antennas,
- Each conveyor line is expected to process 20,000 cases of products per year,
- Each case of products is provided with one tag.

Additionally, he needs to calculate the economic impact of Alpha and Beta errors. If a desired tag is not read, the corresponding product must undergo manual recovery and processing. This process is estimated to be done by a single worker who will dedicate half a day, two times a week to this procedure. George also evaluated a cost of € 4,500.00 for the reverse logistics, and he assumed an average Alpha error of 2.5%. In contrast, if an unwanted tag is read by the system, the costs generated might be estimated at around 0.50 €/tag, as a weekly control of the RFID database costs at around € 10.00 and fixes 20 tags, on average.

Also, as regards fixed costs, the extra hardware of the new RFID system will cost € 10,000, and the software package to manage it, i.e. the middle-

ware connecting the RFID system to the company ERP, will cost € 40,000. The loan used to fund all the hardware and software investment will be amortized in 5 years.

On the other hand, George works hard with colleagues from the sales, marketing, and IT departments to estimate the profit generated by case-level product tagging. Their calculations showed that tagging allows the company to re-allocate two full-time workers from the inventory sector to other tasks. Moreover, that implementation will reduce the inventory and save € 27,000.00, and € 15,000.00 will come from the reduction of returns and re-working. The marketing department also estimated an increase in sales of € 13,000.00 as a result of higher customer satisfaction.

Having those data, George calculates the most remunerative power level value, considering that the actual volume of the company is 300,000 products/year. George decided to use a conservative approach; thus, he considered the worst scenario for cost reduction and new incoming costs.

Additional values: the personnel costs are estimated at € 17.00 per hour, and the working time is 8 a.m.–12 a.m. and 2 p.m.–6 p.m. Furthermore, the company grants seven weeks of holiday per year.

Tasks: Economic evaluations

- Identify variable costs, semi-variable costs, and fixed costs
- Identify the cost driver(s)
- Assign the costs
- Identify the most remunerative combination of antenna types, antenna orientations, and power levels.

References

- Ahamed, N. N., Karthikeyan, P., Anandaraj, S. P., & Vignesh, R. (2020). Sea Food Supply Chain Management Using Blockchain. *2020 6th International Conference on Advanced Computing and Communication Systems (ICACCS)*, 473–476.
- Alotaibi, B. (2019). Utilizing Blockchain to Overcome Cyber Security Concerns in the Internet of Things: A Review. *IEEE Sensors Journal*, 19(23), 10953–10971.
- Attaran, M. (2020). Digital technology enablers and their implications for supply chain management. *Supply Chain Forum: An International Journal*, 1–15.
- Baars, H., Gille, D., & Strüker, J. (2009). Evaluation of RFID applications for logistics: a framework for identifying, forecasting and assessing benefits. *European Journal of Information Systems*, 18(6), 578–591.
- Bertolini, M., Bottani, E., Esposito, G., Rizzi, A., & Romagnoli, G. (2018). Company staff intention to use RFID technology in fashion and apparel retail sector: A UTAUT-based model. *Proceedings of the Summer School Francesco Turco, 2018-Sept*, 450–456.

- Bertolini, M., Romagnoli, G., & Weinhard, A. (2017). Proposing a Value-Added Indicators framework for the apparel and fashion sector: Design and empirical evaluation. *International Journal of RF Technologies*, 8(3), 143–164.
- bin Mohd Nasir, M. A. H., bin Asmuni, M. H., Salleh, N., & Misra, S. (2015). A Review of Student Attendance System Using Near-Field Communication (NFC) Technology. *International Conference on Computational Science and Its Applications*, 738–749.
- Bindi, B., Bandinelli, R., & Rinaldi, R. (2016). RFID and eBIZ implementation in the Textile and Clothing Industry: Evidence of a pilot project. *Proceedings of the 21st Summer School Francesco Turco*, 156–160.
- Bindi, B., Fani, V., Bandinelli, R., Massa, G., & Ciaccio, G. (2018). eBIZ 4.0 new step to digitize the fashion supply chain: preliminary results. *Proceedings of the Summer School Francesco Turco*.
- Blitshteyn, M. (2005). Mastering RFID label converting. *Paper, Film and Foil Converter*.
- Bugg, R., Collins, W., & Gilbert, C. (2018). Applying Radio Frequency IDentification Tags to improve Personnel Safety in Dredging Construction. *THIRTY-FOURTH ANNUAL CONFERENCE*, 557.
- Cao, W., Jiang, P., Liu, B., & Jiang, K. (2018). Real-time order scheduling and execution monitoring in public warehouses based on radio frequency identification. *The International Journal of Advanced Manufacturing Technology*, 95(5–8), 2473–2494.
- Cao, W., Jiang, P., Lu, P., Liu, B., & Jiang, K. (2017). Real-time data-driven monitoring in job-shop floor based on radio frequency identification. *The International Journal of Advanced Manufacturing Technology*, 92(5–8), 2099–2120.
- Caredda, V., Orrù, P. F., Romagnoli, G., Volpi, A., & Zedda, F. (2016). RFID technology for blood tracking: An experimental approach for benchmarking different devices. *International Journal of RF Technologies*, 7(4), 209–228.
- Cilloni, G., Leporati, R., Rizzi, A., & Romagnoli, G. (2019). State of the art of item-level RFID deployments in fashion and apparel retail. *International Journal of RF Technologies*, 10(3–4), 65–88.
- Da Xu, L., He, W., & Li, S. (2014). Internet of things in industries: A survey. *IEEE Transactions on Industrial Informatics*, 10(4), 2233–2243.
- Dalla Chiara, A. (2011). *Analysis of performance and interference effects in Radio Frequency IDentification systems*. PhD Thesis.
- Figueroa, S., Añorga, J., & Arrizabalaga, S. (2019). An attribute-based access control model in RFID systems based on blockchain decentralized applications for healthcare environments. *Computers*, 8(3), 57.
- Finkenzeller, K. (2010). RFID handbook: fundamentals and applications in contactless smart cards, radio frequency identification and near-field communication. *John Wiley & Sons*.
- Gladysz, B., & Santarek, K. (2015). An assessment of technologies with wide range of impact. A case of RFID. *Procedia Manufacturing*, 3, 1966–1973.
- Handojo, A., Lim, R., Octavia, T., & Anggita, J. K. (2018). Museum interactive information broadcasting using indoor positioning system and Bluetooth low energy: A pilot project on Trowulan museum Indonesia. *2018 3rd Technology Innovation Management and Engineering Science International Conference (TIMES-ICON)*, 1–5.

- Hardgrave, B., Waller, M., & Miller, R. (2005). Does RFID reduce out of stocks. A Preliminary Analysis (Information Technology Research Institute, Sam M. Walton College of Business, University of Arkansas, 2005) (<http://itrc.uark.edu/research/display.asp>).
- Heim, G. R., Wentworth Jr, W. R., & Peng, X. (2009). The value to the customer of RFID in service applications. *Decision Sciences*, 40(3), 477–512.
- Holland, W. S., Young II, W. A., & Weckman, G. R. (2011). Facility RFID localization system based on artificial neural networks. *International Journal of Industrial Engineering*, 18(1).
- Iacovidou, E., Purnell, P., & Lim, M. K. (2018). The use of smart technologies in enabling construction components reuse: A viable method or a problem creating solution? *Journal of Environmental Management*, 216, 214–223.
- Ibrahim, A. A., & Kamalrudin, M. (2018). Security requirements and technologies for the internet of things (IOT) applications: A systematic literature review. *Journal of Theoretical & Applied Information Technology*, 96(17).
- Jiang, P., & Cao, W. (2013). An RFID-driven graphical formalized deduction for describing the time-sensitive state and position changes of work-in-progress material flows in a job-shop floor. *Journal of Manufacturing Science and Engineering*, 135(3).
- Keefe, R. F., Wempe, A. M., Becker, R. M., Zimelman, E. G., Nagler, E. S., Gilbert, S. L., & Caudill, C. C. (2019). Positioning methods and the use of location and activity data in forests. *Forests*, 10(5), 458.
- Kereri, J. O., & Adamtey, S. (2019). RFID use in residential/commercial construction industry. *Journal of Engineering, Design and Technology*.
- Kolarovszki, P. (2014). Research of readability and identification of the items in the postal and logistics environment. *Transport and Telecommunication Journal*, 15(3), 196–208.
- Kolarovszki, P., Kolarovszká, Z., Perakovic, D., & Periša, M. (2016). Laboratory testing of active and passive UHF RFID tags. *Transport and Telecommunication Journal*, 17(2), 144–154.
- Landaluce, H., Arjona, L., Perallos, A., Falcone, F., Angulo, I., & Muralter, F. (2020). A Review of IoT Sensing Applications and Challenges Using RFID and Wireless Sensor Networks. *Sensors*, 20(9), 2495.
- Li, C. Z., Zhao, Y., Xiao, B., Yu, B., Tam, V. W. Y., Chen, Z., & Ya, Y. (2020). Research trend of the application of information technologies in construction and demolition waste management. *Journal of Cleaner Production*, 121458.
- Ma, X., & Yang, K. (2013). Transforming sterile processing departments by service-oriented business process management. *International Journal of Business Process Integration and Management*, 6(3), 186–200.
- Manzoor, A. (2016). RFID in Health Care—Building Smart Hospitals for Quality Healthcare. *International Journal of User-Driven Healthcare (IJUDH)*, 6(2), 21–45.
- Motamedi, A., Soltani, M. M., Setayeshgar, S., & Hammad, A. (2016). Extending IFC to incorporate information of RFID tags attached to building elements. *Advanced Engineering Informatics*, 30(1), 39–53.

- Nahian, R. A., & Rana, M. E. (2020). ParkoSet — An intelligent and sustainable car parking management system towards solving traffic congestion problem in developing countries. *Test Engineering and Management*, 83, 254–268. <https://www2.scopus.com/record/display.uri?eid=2-s2.0-85082775738&origin=resultslist&sort=cp-f&src=s&st1=%22ParkoSet++An+in+elligent+and+sustainable+car+parking+management+system+towards+solving+traffic+congestion+problem+in+developing+countries%22&st2=&>
- Niraja, K. S., & Rao, S. S. (2020). Security Challenges and Counter Measures in Internet of Things. *2020 International Conference on Computer Communication and Informatics (ICCCI)*, 1–3.
- Novotny, Á., Dávid, L., & Csáfor, H. (2015). Applying RFID technology in the retail industry—benefits and concerns from the consumer's perspective. *Amfiteatru Economic Journal*, 17(39), 615–631.
- Prakash Chandar, S., Anal, P., & Ganapathyramasamy, N. (2016). Developing of RFID automation technique in material management for various construction projects. *Int. J. Chem. Sci.*, 14, 164–174.
- Riemenschneider, C., Hardgrave, B., & Armstrong, D. (2007). Is there a business case for RFID? *AMCIS 2007 Proceedings*, 325.
- Rizzi, A., Montanari, R., Bertolini, M., Bottani, E., & Volpi, A. (2011). Logistica e tecnologia RFID. Creare valore nella filiera alimentare e nel largo consumo. *Springer, Milano*.
- Rizzi, A., Romagnoli, G., & Thiesse, F. (2016). A new framework for RFID use cases in fashion and apparel retailing. *International Journal of RF Technologies: Research and Applications*, 7(2–3), 105–129.
- Ruppert, T., Jaskó, S., Holczinger, T., & Abonyi, J. (2018). Enabling technologies for operator 4.0: a survey. *Applied Sciences*, 8(9), 1650.
- Shammar, E. A., & Zahary, A. T. (2019). The Internet of Things (IoT): a survey of techniques, operating systems, and trends. *Library Hi Tech*.
- Sidorov, M., Ong, M. T., Sridharan, R. V., Nakamura, J., Ohmura, R., & Khor, J. H. (2019). Ultralightweight mutual authentication RFID protocol for blockchain enabled supply chains. *IEEE Access*, 7, 7273–7285.
- Souryal, M. R., Novotny, D. R., Kuester, D. G., Guerrieri, J. R., & Remley, K. A. (2010). Impact of RF interference between a passive RFID system and a frequency hopping communications system in the 900 MHz ISM band. *2010 IEEE International Symposium on Electromagnetic Compatibility*, 1(3), 495–500. <https://doi.org/10.1109/ISEMC.2010.5711325>
- Sun, C., Jiang, F., & Jiang, S. (2013). Research on RFID Applications in Construction Industry. *Journal of Networks*, 8(5), 1221–1228.
- Talone, P., & Russo, G. (2006). RFID: tecnologia e applicazioni. Fondamenti Delle Tecniche e Cenni Sulle Applicazioni Di Una Tecnologia Silenziosamente Pervasiva.
- Valero, E., Adán, A., & Cerrada, C. (2015). Evolution of RFID applications in construction: A literature review. *Sensors*, 15(7), 15988–16008.
- van Hoek, R. (2019). Exploring blockchain implementation in the supply chain. *International Journal of Operations & Production Management*.

- Xiang, C., Savino, M. M., & Palmieri, A. (2017). Shelf Replenishment with RFID-ERP-Kanban System: A case study in large distribution. *22nd Summer School" Francesco Turco"—Industrial Systems Engineering 2017, 2017*, 292–297.
- Ying, Y., Fischer, D., & Hölscher, U. (2009). Electromagnetic Interference with RFID Readers in Hospitals. *IFMBE Proceedings*, 25(7), 872–875. https://doi.org/10.1007/978-3-642-03885-3_242
- Zhang, L., Ferrero, R., Gandino, F., & Rebaudengo, M. (2013). Evaluation of single and additive interference models for RFID collisions. *Mathematical and Computer Modelling*, 58(5–6), 1236–1248.

Authors



Giovanni Romagnoli
 University of Parma
 Via delle Scienze 181/A
 43124 Parma, Italy
<https://personale.unipr.it/en/ugovdocenti/person/96588>
giovanni.romagnoli@unipr.it



Prof. Dr.-Ing. Dieter Uckelmann
 HFT Stuttgart
 Schellingstr. 24
 70174 Stuttgart
<https://www.hft-stuttgart.de/p/dieter-uckelmann>
dieter.uckelmann@hft-stuttgart.de



Msc, Davide Reverberi
 University of Parma
 Via delle Scienze 181/A
 43124 Parma, Italy
<https://orcid.org/0000-0001-6768-3932>
davide.reverberi@unipr.it



Msc, Maria Ustenko
University of Parma
Via delle Scienze 181/A
43124 Parma, Italy
maria.ustenko@unipr.it

